

VOLUNTARY RECALL NOTICE

To: SRAM Dealers
Subject: VRN090805 - Voluntary Recall Notice - SRAM Chain_10 Speed_Power Lock
From: SRAM LLC
Date: August 2009

To our valued dealers,

SRAM is working with the U.S. Consumer Product Safety Commission to announce a voluntary product recall of SRAM 10 speed chain PowerLock connector links. SRAM has determined there is a potential for the PowerLock connector link outer plate to fail.

This presents a safety issue. As a result SRAM is retrieving and replacing all affected SRAM 10 speed chain PowerLock connector links from the marketplace.

THIS ISSUE IS SAFETY RELATED. SRAM will be advising consumers to stop using this product immediately. In the near future, we will be asking you to help us inform consumers about the recall by posting a Safety Recall Poster in your store, which we will provide you after coordination with the U.S. Consumer Product Safety Commission. Failure of the SRAM 10 speed chain PowerLock connector link, while in use, may result in loss of bicycle control and possible injury.

IMPORTANT

- SRAM 8 speed chains and PowerLinks are NOT affected.
- SRAM 9 speed chains and PowerLinks are NOT affected.
- SRAM 10 speed chains are NOT affected.
- ONLY 10 speed **PowerLock** connector links are affected.

ISSUE

PowerLock connector plate may develop a crack.
 Crack may develop during installation and/or early use.
 Potential occurrence rate - 2.5 connector plates out of 1000

CONSUMERS

SRAM is working with the U.S. Consumer Product Safety Commission to develop the materials to be used to notify consumers about this recall. We will advise you when this recall is going to be announced publicly to consumers. In that public announcement, we will be asking consumers owning one of these products to stop riding immediately and return their chains to any SRAM dealer for verification of the product date stamp and to obtain a free replacement PowerLock.

SRAM DEALER ACTION

SRAM dealers inside the United States - contact SRAM USA (1-800-346-2928) to obtain a return authorization number and replacement Power Lock connector links.

SRAM dealers outside of the United States - contact a SRAM distributor in your region for replacement PowerLock connector links, and to arrange for the return shipment of affected PowerLock connector links.

SRAM distributor contact information is located at www.sram.com (www.sram.com/en/locator/distributors.php).

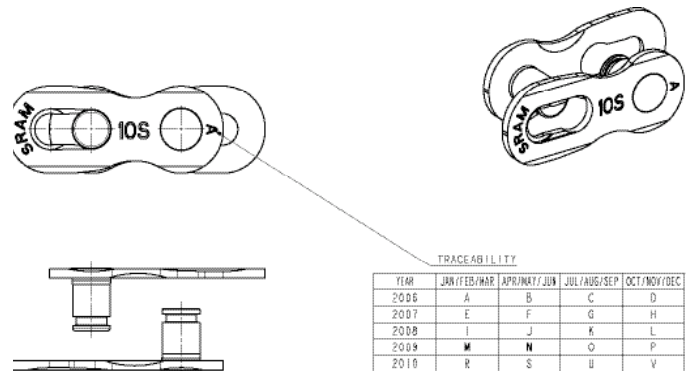

Fig. A - Date Code Identification - Letters M and N



VOLUNTARY RECALL NOTICE

PRODUCT AFFECTED

SRAM PowerLock Connector Link (for SRAM 10 Speed Chain)

POWERLOCKS AFFECTED (PRODUCTION RANGE) - DATE CODE

Date codes **M** and **N** (on PowerLock ONLY). Date code letter is stamped onto end of each PowerLock connector link outer plate. To verify date stamp, check BOTH PowerLock connector link outer plates! See Fig. A.

CHAIN MODELS/PART NUMBERS - POTENTIALLY AFFECTED - AFTERMARKET:

85.2737.270.074	PowerLock Chain Connector 10-speed (4 pcs)
91.2712.114.005	Chain PC 1090R HollowPin 114 links PowerLock 10-speed
90.2712.114.005	Chain PC 1090 HollowPin 114 links PowerLock 10-speed
89.2711.114.005	Chain PC 1070 HollowPin 114 links PowerLock 10-speed
93.2712.114.005	Chain PC 1050 114 links PowerLock 10-speed
92.2711.114.005	Chain PC 1030 114 links PowerLock 10-speed

SRAM DEALER CUSTOMERS - PRODUCT IDENTIFICATION PROCEDURES:

PowerLock connector links date-stamped with letters **M** and **N** must be removed and replaced with new PowerLock connector links date-stamped with letters **other than M and N**.

All PowerLock connector links date-stamped with letters **M** and **N** must be returned to SRAM. Please make arrangements with your SRAM Sales or Customer Service representative.

Aftermarket 10 Speed Chain PowerLock Connector Links - Packaged

1. PowerLock Connector Link (4 pack):

- Connector link outer plates are visible through plastic packaging.
- Locate the letter stamped at the end of each connector link.
- Packaged connector links with letters **M** and **N** should be removed from inventory and set aside for shipment back to SRAM (packaging unopened).
- Contact SRAM Dealer Service for replacement PowerLock connector links and to arrange for return shipment back to SRAM.

2. PowerLock Connector Link in packaged aftermarket 10 speed chains:

- All SRAM 10 speed chains include a PowerLock Connector link located in the center of the packaged chain.
- Carefully peel the plastic label from the back of the chain box enough to open the box lid.
- Remove each PowerLock connector link from the center of the chain.
- Locate the letter stamped at the end of each connector link.
- PowerLock connector links with letters **M** and **N** should be removed from the chain package and set aside for shipment back to SRAM.
- Contact SRAM Dealer Service for replacement PowerLock connector links and to arrange for return shipment of affected PowerLock connector links back to SRAM.
- Replace affected PowerLock connector links with new connector links provided at no charge by SRAM.
- Return packaged chain to store inventory.



VOLUNTARY RECALL NOTICE

10 Speed Chain PowerLock Connector Links - installed chain on bicycles (new and used)

1. PowerLock Connector Link - identification and action

- Inspect all new and used bicycles in your store that include a SRAM 10 speed chain.
- Locate the PowerLock connector link on chain.
- Locate letter stamped onto end of PowerLock connector link (See fig. 1).
- PowerLock connector links with letters **M** and **N** should be removed from the chain and set aside for shipment back to SRAM.
- Contact SRAM Dealer Service for replacement PowerLock connector links and to arrange for return shipment of affected PowerLock connector links back to SRAM.
- Replace affected PowerLock connector links with new connector links provided at no charge by SRAM.

2. PowerLock Connector Link - removal and replacement

- Replace PowerLock connector link if date stamp letter is **M** or **N**.
- Remove affected PowerLock connector link with chain tool (both pins). Drive the larger diameter end of pin out of link out by positioning pin removal tool against small pin diameter (See fig. 2). Repeat; second pin (See fig. 3).
- Install new PowerLock connector link (See fig. 4).
 - Fit chain, insert both halves of the PowerLock into the chain ends (Fig. 5) and bring the ends together (Fig. 6) on the bottom side of the drivetrain (no tension side).
 - Pull chain apart until you feel some resistance (Fig. 7).
 - Rotate the chain so the PowerLock is positioned on the top side of the drivetrain.
 - Pedal forward while holding bike firmly in place until you hear click sound. The Power Lock is now on its place and safely closed.

Please contact SRAM or your SRAM distributor if you have further questions. We apologize for this inconvenience and appreciate your continued support.

Thank you,

SRAM LLC

